

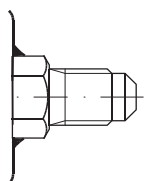

Eliminator® Liquid line filter driers,
DCL and DML

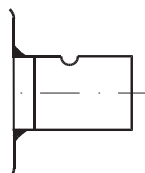

Flare connection



Solder connection (copper)

Contents

	Page
Introduction.....	3
Features.....	3
Approvals.....	3
Technical data.....	4
Technical data and capacities.....	4
Ordering.....	6
Identification.....	8
Selection.....	8
Selection example.....	8
Design and function.....	9
Dimensions and weights - Flare connections.....	9
Dimensions and weights - Solder connections.....	11
Conversions.....	12

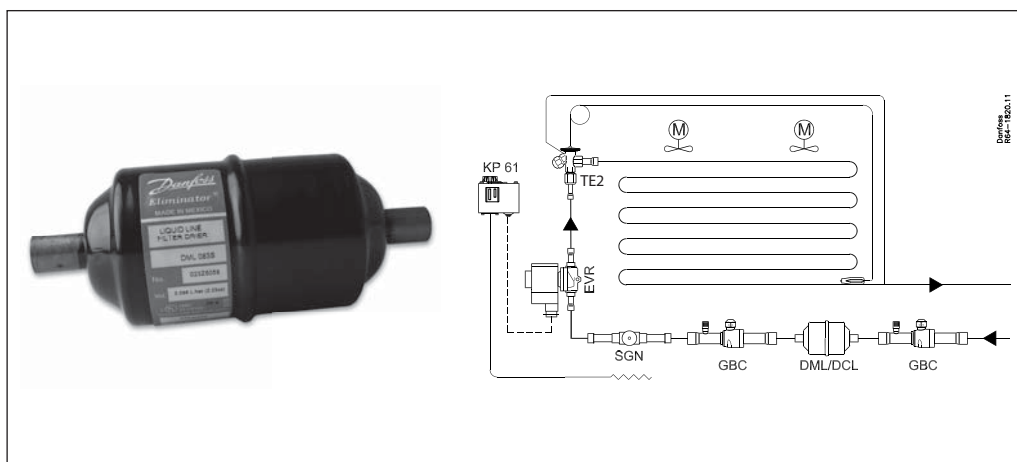
Introduction

Eliminator® liquid line filter driers protect refrigeration and air-conditioning systems from moisture, acids, and solid particles. With these contaminants eliminated, systems are safer from harmful chemical reactions and from abrasive impurities.

There are two types of **Eliminator**® cores. Type DML driers have a core composition of 100% Molecular Sieve, while type DCL contain 80% Molecular Sieve with 20% activated alumina.

All **Eliminator**® driers have a solid core with binding material held to an absolute minimum. Core selection is primarily based on the refrigerant oil used in the system.

Eliminator® type DML, with a solid core of 100% Molecular Sieve, is optimized for use with HFC refrigerants and polyolester (POE) or polyalkyl glycol (PAG) oils. Type DML driers are designed for applications requiring high water adsorption, and can be used with any manufacturer's compressor. Because type DML driers contain no activated alumina, oil additives will not be depleted.

Eliminator® type DCL, with a solid core of 80% Molecular Sieve and 20% activated alumina, is the drier of choice for systems with HCFC and CFC refrigerants and mineral or alkyl benzene oils. Type DCL driers are particularly suited for systems that operate at high condensing temperatures and require high drying capacity.

Features
The Core
Type DML

- 100% 3Å Molecular Sieve core.
- High drying capacity minimizing the risk of acid formation (hydrolysis).
- Optimized for HFC refrigerants (R134a, R404A, R410A, etc.) with POE or PAG oils. Compatible with R22.
- Will not deplete oil additives.

Type DCL

- 80% 3Å Molecular Sieve with 20% activated alumina.
- Perfect core blend for systems that operate at high condensing temperatures and require high drying capacity.
- Optimized for CFC and HCFC refrigerants (R22, R502, etc.) with mineral or alkyl benzene oils. Compatible with HFC's and refrigerant blends.

The Shell

- UL approved for MWP up to 46 bar (667 psig).
- Available with solder (copper) and flare connections.
- Compact 3 cubic inches drier ideal for refrigeration and air conditioning units.
- Corrosion resistant powder-painted finish. Can be used in all environments including marine applications.
- Allows installation with any orientation provided the arrow is in the flow direction.
- Available in sizes from 3 to 75 cubic inches.

The Filter

- 25 µm (0.001 in.) filter provides high retention with minimal pressure drop.
- Thermally stable up to 120°C (250°F).

Approvals

UL US UL file no. SA 6398
PED 97/23/EC - a3p3

Technical data

Surface and volume

Filter	Solid core surface [cm ²]	Solid core volume [cm ³]	Filter drier volume (shell volume) [l]	Filter drier volume (net volume) [l]
DML/DCL 03	82	41	0.08	0.038
DML/DCL 05	95	67	0.12	0.051
DML/DCL 08	131	104	0.17	0.065
DML/DCL 16	220	234	0.36	0.122
DML/DCL 30	378	494	0.72	0.224
DML/DCL 41	510	681	0.97	0.286
DML/DCL 60	756	988	1.34	0.352
DML/DCL 75	1019	1363	1.81	0.450

Acid capacity

Filter	Acid capacity [g]
DCL 03	0.58
DCL 05	0.87
DCL 08	1.36
DCL 16	3.12
DCL 30	6.40
DCL 41	8.90
DCL 60	12.80
DCL 75	17.80

Temperature range

– 40 to 70°C (–40 to 160°F)

Technical data and capacities

DML

Drying and liquid capacity - Type DML

R134a, R507, R404A, R22, R407C, R410A

Type	Drying capacity [kg refrigerant] ¹⁾						Liquid capacity [kW] ²⁾			Max Working Pressure PS [bar]
	R134a		R404A R507		R22, R407C R410A		R134a	R404A R507	R22 R407C R410A	
	24°C	52°C	24°C	52°C	24°C	52°C				
DML 032/032s	5.5	5	7.5	4.5	4.5	4	7	5	7	46
DML 032.5s	5.5	5	7.5	4.5	4.5	4	9	7	10	46
DML 033/033s	5.5	5	7.5	4.5	4.5	4	17	13	19	46
DML 034s	5.5	5	7.5	4.5	4.5	4	24	17	26	46
DML 052/052s	8.5	8	13	7.5	8	7	7	5	8	46
DML 052.5s	8.5	8	13	7.5	8	7	9	7	10	46
DML 053/053s	8.5	8	13	7.5	8	7	18	14	19	46
DML 054s	8.5	8	13	7.5	8	7	25	18	27	46
DML 055s	8.5	8	13	7.5	8	7	34	25	38	46
DML 082/082s	12.5	12	20	11.5	12.5	11	7	5	8	46
DML 082.5s	12.5	12	20	11.5	12.5	11	10	8	11	46
DML 083/083s	12.5	12	20	11.5	12.5	11	19	14	21	46
DML 084/084s	12.5	12	20	11.5	12.5	11	26	20	29	46
DML 085/085s	12.5	12	20	11.5	12.5	11	42	31	46	46
DML 162/162s	27	25.5	43.5	24	27	23	7	5	8	46
DML 162.5s	27	25.5	43.5	24	27	23	10	8	11	46
DML 163/163s	27	25.5	43.5	24	27	23	22	16	24	46
DML 164/164s	27	25.5	43.5	24	27	23	30	22	33	46
DML 165/165s	27	25.5	43.5	24	27	23	43	30	47	46
DML 166/166s	27	25.5	43.5	24	27	23	44	31	48	35
DML 167s	27	25.5	43.5	24	27	23	44	31	48	35
DML 303/303s	57	54	92.5	51	57	48.5	21	15	23	46
DML 304/304s	57	54	92.5	51	57	48.5	31	22	34	46
DML 305/305s	57	54	92.5	51	57	48.5	45	33	49	46
DML 306/306s	57	54	92.5	51	57	48.5	62	45	68	35
DML 307s	57	54	92.5	51	57	48.5	62	45	68	35
DML 309s	57	54	92.5	51	57	48.5	62	45	68	30
DML 413	80	75	130	70	80	74	25	18	27	46
DML 414/414s	80	75	130	70	80	74	32	23	35	46
DML 415/415s	80	75	130	70	80	74	53	37	58	46
DML 417s	80	75	130	70	80	74	91	65	100	35
DML 419s	80	75	130	70	80	74	91	65	100	30
DML 604s	113	107	185	101	114	97	27	20	31	46
DML 607s	113	107	185	101	114	97	75	54	82	35
DML 609s	113	107	185	101	114	97	87	64	95	30
DML 757s	160	150	260	140	160	148	82	60	90	35
DML 759s	160	150	260	140	160	148	94	68	102	30

¹⁾ Drying capacity is based on following moisture content test standards before and after drying:
R134a:
 From 1050 ppm W to 75 ppm W.
 If drying to 50 ppm W is required, reduce stated capacities by 15%.
R404A, R507:
 From 1020 ppm W to 30 ppm W.
R407C:
 From 1020 ppm W to 30 ppm W.
R410A:
 From 1050 ppm W to 60 ppm W.
R22:
 From 1050 ppm W to 60 ppm W in accordance with ARI 710-86.
R12:
 From 565 ppm W to 15 ppm W in accordance with ARI 710-86.
R502:
 From 1020 ppm W to 30 ppm W in accordance with ARI 710-86.

²⁾ Given in accordance with ARI 710-86 for
 t_e = –15°C (5°F),
 t_c = 30°C (85°F) and
 Δp = 0.07 bar (1 psig).

Technical data and capacities

DCL

Drying and liquid capacity - Type DCL

R134a, R507, R404A, R407C, R410A

Type	Drying capacity [kg refrigerant] ¹⁾						Liquid capacity [kW] ²⁾			Max Working Pressure PS [bar]
	R134a		R404A R507		R407C R410A		R134a	R404A R507	R407C R410A	
	24°C	52°C	24°C	52°C	24°C	52°C				
DCL 032/032s	4.5	4	7	3.5	4	3.5	7	5	7	46
DCL 032.5s	4.5	4	7	3.5	4	3.5	9	7	10	46
DCL 033/033s	4.5	4	7	3.5	4	3.5	17	13	19	46
DCL 052/052s	6.5	6	10	5.5	6	5.5	7	5	8	46
DCL 052.5s	6.5	6	10	5.5	6	5.5	9	7	10	46
DCL 053/053s	6.5	6	10	5.5	6	5.5	18	14	19	46
DCL 082/082s	10	9	16	8	9.5	9	7	5	8	46
DCL 082.5s	10	9	16	8	9.5	9	10	8	11	46
DCL 083/083s	10	9	16	8	9.5	9	19	14	21	46
DCL 084/084s	10	9	16	8	9.5	9	26	20	29	46
DCL 162/162s	24	22	37	20	22	20	7	5	8	46
DCL 162.5s	24	22	37	20	22	20	10	8	11	46
DCL 163/163s	24	22	37	20	22	20	22	16	24	46
DCL 164/164s	24	22	37	20	22	20	30	22	33	46
DCL 165/165s	24	22	37	20	22	20	43	30	47	46
DCL 166/166s	24	22	37	20	22	20	43	30	47	35
DCL 167s	24	22	37	20	22	20	43	30	47	35
DCL 303/303s	47	44	77	41	44	41	21	15	23	46
DCL 304/304s	47	44	77	41	44	41	31	22	34	46
DCL 305/305s	47	44	77	41	44	41	45	33	49	46
DCL 306/306s	47	44	77	41	44	41	62	45	68	35
DCL 307s	47	44	77	41	44	41	62	45	68	35
DCL 309s	47	44	77	41	44	41	62	45	68	30
DCL 413	65	61	106	56	61	56	25	18	27	46
DCL 414/414s	65	61	106	56	61	56	32	23	35	46
DCL 415/415s	65	61	106	56	61	56	53	37	58	46
DCL 417s	65	61	106	56	61	56	91	65	100	35
DCL 419s	65	61	106	56	61	56	91	65	100	30
DCL 604s	94	76	150	82	89	82	27	20	31	46
DCL 607s	94	76	150	82	89	82	75	54	82	35
DCL 609s	94	76	150	82	89	82	87	64	92	30
DCL 757s	130	128	212	114	121	112	82	60	90	35
DCL 759s	130	128	212	114	121	112	94	68	102	30

¹⁾ Drying capacity is based on following moisture content test standards before and after drying:

R134a:
From 1050 ppm W to 75 ppm W. If drying to 50 ppm W is required, reduce stated capacities by 15%.

R404A, R507:
From 1020 ppm W to 30 ppm W.

R407C:
From 1020 ppm W to 30 ppm W.

R410A:
From 1050 ppm W to 60 ppm W.

R22:
From 1050 ppm W to 60 ppm W in accordance with ARI 710-86.

R12:
From 565 ppm W to 15 ppm W in accordance with ARI 710-86.

R502:
From 1020 ppm W to 30 ppm W in accordance with ARI 710-86.

²⁾ Given in accordance with ARI 710-86 for
t_e = -15°C (5°F),
t_c = 30°C (85°F) and
Δp = 0.07 bar (1 psig).

R22, R12, R502

Type	Drying capacity [kg refrigerant] ¹⁾						Liquid capacity [kW] ²⁾			Max Working Pressure PS [bar]
	R22		R12		R502		R22	R12	R502	
	24°C	52°C	24°C	52°C	24°C	52°C				
DCL 032/032s	4	3.5	15	15	7	3.5	7	6	5	46
DCL 032.5s	4	3.5	15	15	7	3.5	10	8	7	46
DCL 033/033s	4	3.5	15	15	7	3.5	19	14	13	46
DCL 052/052s	5.5	5	20	20	10	5	8	6	5	46
DCL 052.5s	5.5	5	20	20	10	5	10	8	8	46
DCL 053/053s	5.5	5	20	20	10	5	19	15	14	46
DCL 082/082s	9	8	30	30	15	8	8	6	5	46
DCL 082.5s	9	8	30	30	15	8	10	8	8	46
DCL 083/083s	9	8	30	30	15	8	21	15	14	46
DCL 084/084s	9	8	30	30	15	8	29	22	20	46
DCL 162/162s	20	19	70	70	35	18	8	6	5	46
DCL 162.5s	20	19	70	70	35	18	13	10	9	46
DCL 163/163s	20	19	70	70	35	18	24	18	16	46
DCL 164/164s	20	19	70	70	35	18	33	24	22	46
DCL 165/165s	20	19	70	70	35	18	47	35	30	46
DCL 166/166s	20	19	70	70	35	18	47	35	30	35
DCL 167s	20	19	70	70	35	18	47	35	30	35
DCL 303/303s	42	41	140	140	75	37.5	23	17	15	46
DCL 304/304s	42	41	140	140	75	37.5	34	25	22	46
DCL 305/305s	42	41	140	140	75	37.5	49	37	33	46
DCL 306/306s	42	41	140	140	75	37.5	68	51	45	35
DCL 307s	42	41	140	140	75	37.5	68	51	45	35
DCL 309s	42	41	140	140	75	37.5	68	51	45	30
DCL 413	59	56	200	200	100	50	26	20	18	46
DCL 414/414s	59	56	200	200	100	50	35	26	23	46
DCL 415/415s	59	56	200	200	100	50	58	43	37	46
DCL 417s	59	56	200	200	100	50	100	74	65	35
DCL 419s	59	56	200	200	100	50	100	74	65	30
DCL 604s	84	80	250	250	150	75	29	22	19	46
DCL 607s	84	80	250	250	150	75	83	63	54	35
DCL 609s	84	80	250	250	150	75	97	73	63	30
DCL 757s	120	110	300	300	200	100	91	69	59	35
DCL 759s	120	110	300	300	200	100	104	79	68	30

Ordering

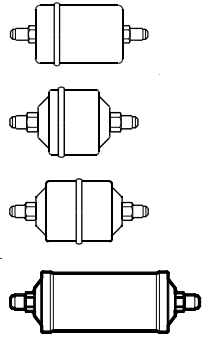

Flare

DCL

Type	Conn.		Multipack	Industrialpack for OEM only	
	in.	mm	Code no.	Code no.	Qty.
DCL 032	1/4	6	023Z5000*	023Z8075	28
DCL 032	1/4	6	023Z5075		
DCL 033	3/8	10	023Z5001*		
DCL 033	3/8	10	023Z5089		
DCL 052	1/4	6	023Z5002	023Z8002 023Z8003	16
DCL 053	3/8	10	023Z5003		
DCL 082	1/4	6	023Z5004	023Z8004 023Z8005 023Z8006	16
DCL 083	3/8	10	023Z5005		
DCL 084	1/2	12	023Z5006		
DCL 162	1/4	6	023Z5007	023Z8007 023Z8008 023Z8009 023Z8010	12
DCL 163	3/8	10	023Z5008		
DCL 164	1/2	12	023Z5009		
DCL 165	5/8	16	023Z5010		
DCL 166	3/4	19	023Z5011		
DCL 303	3/8	10	023Z0012		
DCL 304	1/2	12	023Z0013		
DCL 305	5/8	16	023Z0014		
DCL 306	3/4	19	023Z0156		
DCL 413	3/8	10	023Z0101		
DCL 414	1/2	12	023Z0102		
DCL 415	5/8	16	023Z0103		

* Wire mesh in filter drier outlet

Solder (copper)

DCL

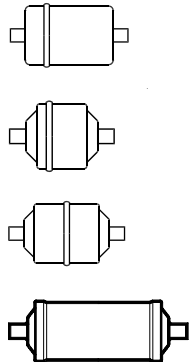

Type	Conn.	Multipack	Industrialpack for OEM only		Conn.	Multipack	Industrialpack for OEM only	
	in.	Code no.	Code no.	Qty.		mm	Code no.	Code no.
DCL 032s	1/4	023Z5013*	023Z8013*	28	6	023Z5012*	023Z8012*	28
DCL 032.5s	5/16	023Z5014	023Z8014*					
DCL 033s	3/8	023Z5015						
DCL 052s	1/4	023Z5018	023Z8018	16	6	023Z5017	023Z8017	16
DCL 052.5s	5/16	023Z5114						
DCL 053s	3/8	023Z5019	023Z8019					
DCL 082s	1/4	023Z5022	023Z8022	16	6	023Z5021		16
DCL 082.5s	5/16	023Z5116						
DCL 083s	3/8	023Z5023	023Z8023					
DCL 084s	1/2	023Z5026	023Z8026					
DCL 162s	1/4	023Z5028	023Z8032 023Z8033	12	6	023Z5027	023Z8030 023Z8033	12
DCL 162.5s	5/16	023Z5118						
DCL 163s	3/8	023Z5029						
DCL 164s	1/2	023Z5032						
DCL 165s	5/8	023Z5033						
DCL 166s	3/4	023Z5070						
DCL 166s	3/4	023Z5070						
DCL 167s	7/8	023Z5034						
DCL 303s	3/8	023Z0030	023Z3030	8	10	023Z0196	023Z3198 023Z3032 023Z3034	8
DCL 304s	1/2	023Z0031						
DCL 305s	5/8	023Z0032						
DCL 306s	3/4	023Z0033						
DCL 307s	7/8	023Z0034						
DCL 307s	7/8	023Z0034						
DCL 309s	1 1/8	023Z0035						
DCL 414s	1/2	023Z0104		12	12	023Z0227		
DCL 415s	5/8	023Z0105						
DCL 417s	7/8	023Z0106						
DCL 419s	1 1/8	023Z0107						
DCL 604s	1/2	023Z0241		28	12	023Z0221		
DCL 607s	7/8	023Z0036						
DCL 609s	1 1/8	023Z0037						
DCL 757s	7/8	023Z0115		28	22	023Z0115		
DCL 759s	1 1/8	023Z0116						

* Wire mesh in filter drier outlet

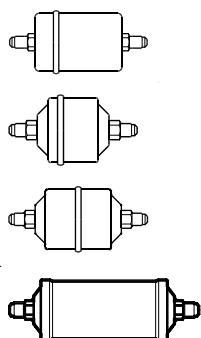
Ordering (cont.)

Flare
DML

Type	Conn.		Multipack	Industrialpack for OEM only	
	in.	mm	Code no.	Code no.	Qty.
DML 032	1/4	6	023Z5035*	023Z8035*	28
DML 033	3/8	10	023Z5036*	023Z8036*	
DML 033	3/8	10	023Z5090	023Z8090	
DML 052	1/4	6	023Z5037	023Z8037	16
DML 053	3/8	10	023Z5038	023Z8038	
DML 082	1/4	6	023Z5039	023Z8039	16
DML 083	3/8	10	023Z5040	023Z8040	
DML 084	1/2	12	023Z5041	023Z8041	
DML 085	5/8	16	023Z5073	023Z8073	
DML 162	1/4	6	023Z5042	023Z8042	12
DML 163	3/8	10	023Z5043	023Z8043	
DML 164	1/2	12	023Z5044	023Z8044	
DML 165	5/8	16	023Z5045	023Z8045	
DML 166	3/4	19	023Z5046	023Z8046	
DML 303	3/8	10	023Z0049	023Z3049	
DML 304	1/2	12	023Z0050	023Z3050	
DML 305	5/8	16	023Z0051	023Z3051	
DML 306	3/4	19	023Z0193	023Z3193	
DML 413	3/8	10	023Z0108	023Z3108	6
DML 414	1/2	12	023Z0109	023Z3109	
DML 415	5/8	16	023Z0110	023Z3110	

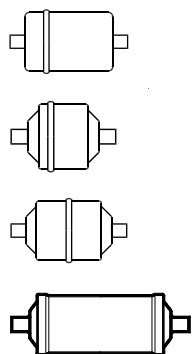
* Wire mesh in filter drier outlet

Solder (copper)
DML

Type	Conn.	Multipack	Industrialpack for OEM only		Conn.	Multipack	Industrialpack for OEM only	
	in.	Code no.	Code no.	Qty.		mm	Code no.	Code no.
DML 032s	1/4	023Z5048*	023Z8048*	28	6	023Z5047*	023Z8047*	28
DML 032.5s	5/16	023Z5049	023Z8049		8	023Z5049	023Z8049	
DML 033s	3/8	023Z5050	023Z8050*		10	023Z5051	023Z8051*	
DML 034s	1/2	023Z5121			12	023Z5123		
DML 052s	1/4	023Z5053		16	6	023Z5052	023Z8052	16
DML 052.5s	5/16	023Z5115			8	023Z5115		
DML 053s	3/8	023Z5054	023Z8054		10	023Z5055	023Z8055	
DML 054s	1/2	023Z5101			12	023Z5099		
DML 055s	5/8	023Z5100			16	023Z5100		
DML 082s	1/4	023Z5057		16	6	023Z5056		
DML 082.5s	5/16	023Z5117			8	023Z5117		
DML 083s	3/8	023Z5058			10	023Z5059		
DML 084s	1/2	023Z5061	023Z8061		12	023Z5060		
DML 085s	5/8	023Z5072			16	023Z5072		
DML 162s	1/4	023Z5063	023Z8133	12	6	023Z5062		12
DML 162.5s	5/16	023Z5119			8	023Z5119		
DML 163s	3/8	023Z5064	023Z8134		10	023Z5065		
DML 164s	1/2	023Z5067	023Z8067		12	023Z5066		
DML 165s	5/8	023Z5068	023Z8068		16	023Z5068	023Z8068	
DML 166s	3/4	023Z5071	023Z8071		19	023Z5071	023Z8071	
DML 167s	7/8	023Z5069			22	023Z5069		
DML 303s	3/8	023Z0067			8	10	023Z0197	
DML 304s	1/2	023Z0068		12		023Z0199		
DML 305s	5/8	023Z0069	023Z3069	16		023Z0069	023Z3069	
DML 306s	3/4	023Z0070		19		023Z0070		
DML 307s	7/8	023Z0071	023Z3071	22		023Z0071	023Z3071	
DML 309s	1 1/8	023Z0072		28		023Z0201		
DML 414s	1/2	023Z0111		6	12	023Z0228		6
DML 415s	5/8	023Z0112			16	023Z0112		
DML 417s	7/8	023Z0113	023Z3113		22	023Z0113	023Z3113	
DML 419s	1 1/8	023Z0114	023Z3114		28	023Z0203		
DML 604s	1/2	023Z0224		28	12	023Z0229		
DML 607s	7/8	023Z0073			22	023Z0073		
DML 609s	1 1/8	023Z0074			28	023Z0205		
DML 757s	7/8	023Z0117	023Z3117	4	22	023Z0117	023Z3117	4
DML 759s	1 1/8	023Z0118	023Z3118		28	023Z0207		

* Wire mesh in filter drier outlet

Identification

Example for type codes

D C L 05 3 s

Type codes

Filter drier	D	
Solid core	C	80 / 20% composite core
	M	100% Molecular Sieve core
Application	L	Liquid line
Size (volume)	03	3 in ³
	05	5 in ³
	08	8 in ³
	16	16 in ³
	30	30 in ³
	41	41 in ³
	60	60 in ³
	75	75 in ³
Connection (filter connection in 1/8 of an inch increments)	2	1/4 in. / 6mm
	2.5	5/16 in. / 8 mm
	3	3/8 in. / 10 mm
	4	1/2 in. / 12 mm
	5	5/8 in. / 16 mm
	6	3/4 in. / 18 (19) mm
	7	7/8 in. / 22 mm
	9	1 1/8 in. / 28 mm
Connection type	(blank)	Flare connection
	s	Solder connection

Selection

- 1) For CFC systems, DCL filter driers are recommended. In these systems, circumstances may require the use of a filter drier with acid adsorbing properties.
- 2) Use of filter driers containing activated alumina are not recommended in systems with oils containing additives.

Type selection is made considering the application

		DCL	DML
Refrigerant	HFC	Can be used	Recommended
	HCFC	Recommended	Can be used
	CFC	Recommended	Not recommended 1)
Oil	Mineral or AB	Recommended	Can be used
	POE or PAG, pure	Can be used	Recommended
	POE or PAG, with additives	Not recommended 2)	Recommended

Selection example SI-units

Select the appropriate type (DML or DCL) based on refrigerant and oil type. Then select the drier size based on the adsorption and liquid capacity required.

a. Amount of charge: 25 kg R134a at t_L = 24°C To dry 25 kg R134a at 24°C from 1050 to 60 ppm moisture, a DML 16 is necessary.

b. Cooling capacity: Q_e = 20 kW To obtain a mass flow corresponding to 20 kW cooling capacity with a DML 16 filter

drier, a 3/8 inch connection must be chosen. Larger connections can be chosen in accordance with the liquid line dimension.

c. Result
DML 163 or DML 163s can be used.

If the initial moisture content is very small or a planned change of the filter drier is considered, a smaller filter drier size can be chosen.

Type	Drying capacity [kg refrigerant] 1)						Liquid capacity [kW] 2)			Max Working Pressure PS [bar]
	R134a		R404A R507		R22, R407C R410A		R134a	R404A R507	R22 R407C R410A	
	24°C	52°C	24°C	52°C	24°C	52°C				
DML 032/032s	5.5	5	7.5	4.5	4.5	4	7	5	7	46
DML 032.5s	5.5	5	7.5	4.5	4.5	4	9	7	10	46
DML 035				4.5	4.5	4	17			46

DML 162/162s	27	25.5	43.5	24	27	23	10	8	8	46
DML 162.5s	27	25.5	43.5	24	27	23	10	8	11	46
DML 163/163s	27	25.5	43.5	24	27	23	22	16	24	46
DML 164/164s	27	25.5	43.5	24	27	23	30	22	33	46
DML 165/165s	27	25.5	43.5	24	27	23	43	30	47	46
DML 166/166s				24	27	23	44	31		46
DML 166.5s				24	27	23	44	31		46

Design and function

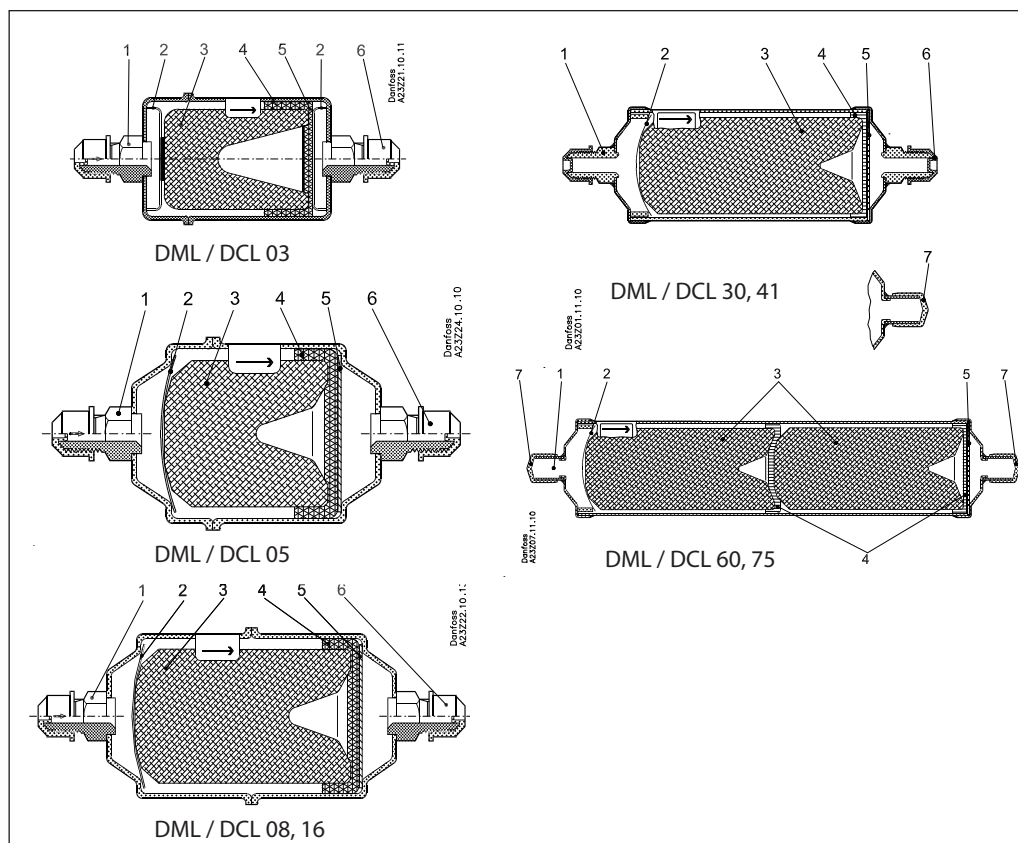

- 1. Inlet
- 2. Spring
- 3. Solid core
- 4. Polyester mat
- 5. Perforated plate
- 6. Seal cap, flare connection
- 7. Seal cap, solder connection

The relatively large diameter of the filter drier means that the liquid flow velocity is suitably low and the pressure drop minimal.

Powder formation is eliminated because the solid core grains are bonded and cannot move against each other.

Dimensions and weights

Flare connections

Type		A	A ₁	A ₂	L	D ₁	D ₂	Weight
DCL/DML 032	mm	66	16	50	110	46	43	0.20 kg
DCL/DML 033	mm	66	16	50	123	46	43	0.23 kg

Dimensions and weights
(cont.)

Flare connections

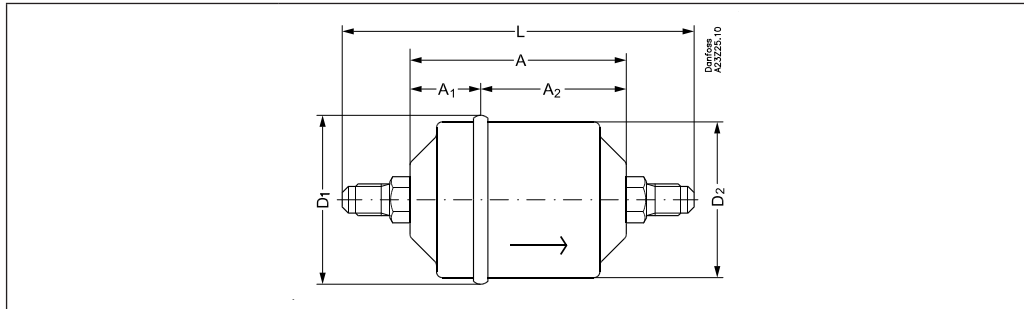

Type		A	A ₁	A ₂	L	D ₁	D ₂	Weight
DCL/DML 052	mm	75	24.5	50.5	119	58	54	0.39 kg
DCL/DML 053	mm	75	24.5	50.5	132	58	54	0.42 kg

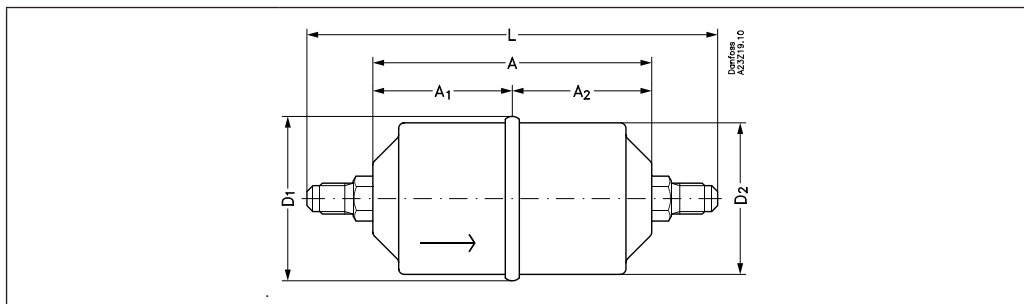

Type		A	A ₁	A ₂	L	D ₁	D ₂	Weight
DCL/DML 082	mm	101	50.5	50.5	145	58	54	0.40 kg
DCL/DML 083	mm	101	50.5	50.5	158	58	54	0.44 kg
DCL/DML 084	mm	101	50.5	50.5	166	58	54	0.48 kg
DML 085	mm	101	50.5	50.5	175	58	54	0.52 kg
DCL/DML 162	mm	110	55	55	154	80	76	0.79 kg
DCL/DML 163	mm	110	55	55	167	80	76	0.82 kg
DCL/DML 164	mm	110	55	55	175	80	76	0.87 kg
DCL/DML 165	mm	110	55	55	184	80	76	0.91 kg
DCL/DML 166	mm	110	55	55	182	80	76	0.99 kg

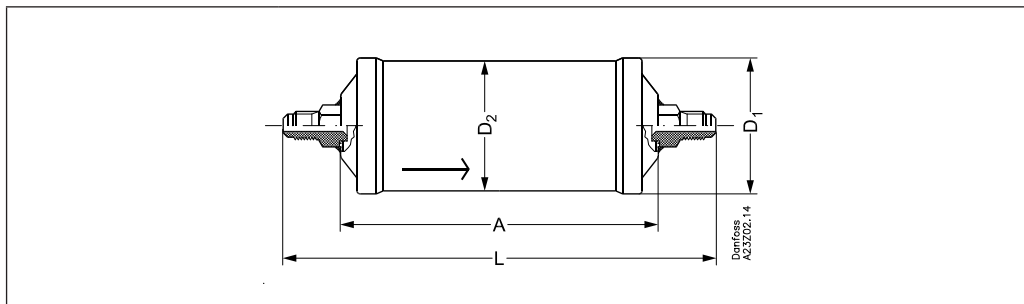

Type		A	A ₁	A ₂	L	D ₁	D ₂	Weight
DCL/DML 303	mm	186	-	-	243	80	76	1.33 kg
DCL/DML 304	mm	186	-	-	251	80	76	1.38 kg
DCL/DML 305	mm	186	-	-	260	80	76	1.42 kg
DCL/DML 306	mm	186	-	-	258	80	76	1.49 kg
DCL/DML 413	mm	187	-	-	244	93	89	1.86 kg
DCL/DML 414	mm	187	-	-	252	93	89	1.91 kg
DCL/DML 415	mm	187	-	-	261	93	89	1.95 kg

Dimensions and weights
 (cont.)

Solder connections

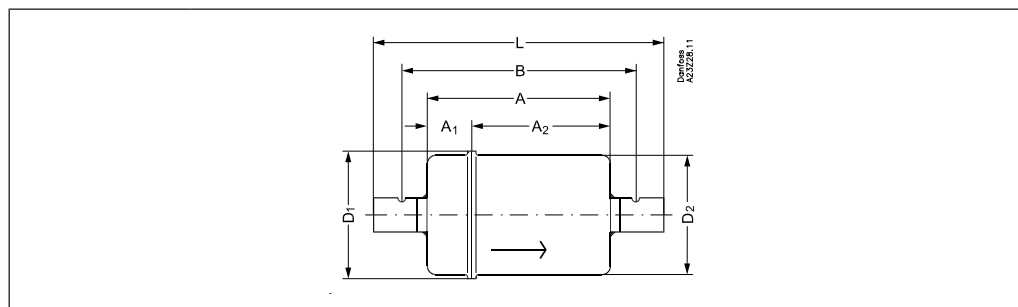

Type		A	A ₁	A ₂	B	L	D ₁	D ₂	Weight
DCL/DML 032s	mm	66	16	50	82	98	46	43	0.18 kg
DCL/DML 032.5s	mm	66	16	50	84	102	46	43	0.19 kg
DCL/DML 033s	mm	66	16	50	85	104	46	43	0.19 kg
DCL/DML 034s	mm	66	16	50	87	108	46	43	0.20 kg

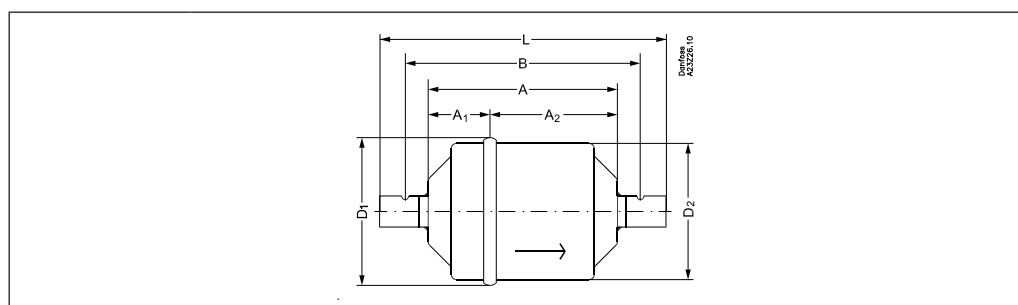

Type		A	A ₁	A ₂	B	L	D ₁	D ₂	Weight
DCL/DML 052s	mm	75	24.5	50.5	91	107	58	54	0.37 kg
DCL/DML 052.5s	mm	75	24.5	50.5	93	111	58	54	0.38 kg
DCL/DML 053s	mm	75	24.5	50.5	94	113	58	54	0.38 kg
DML 054s	mm	75	24.5	50.5	96	117	58	54	0.39 kg
DML 055s	mm	75	24.5	50.5	99	123	58	54	0.40 kg

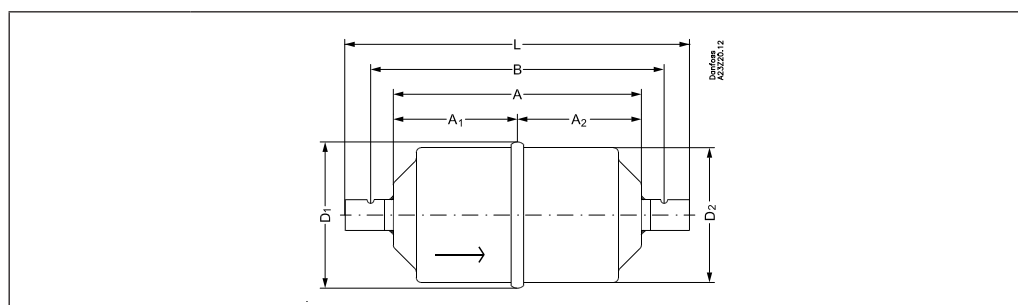

Type		A	A ₁	A ₂	B	L	D ₁	D ₂	Weight
DCL/DML 082s	mm	101	50.5	50.5	117	133	58	54	0.38 kg
DCL/DML 082.5s	mm	101	50.5	50.5	119	137	58	54	0.39 kg
DCL/DML 083s	mm	101	50.5	50.5	120	139	58	54	0.39 kg
DCL/DML 084s	mm	101	50.5	50.5	122	143	58	54	0.40 kg
DML 085s	mm	101	50.5	50.5	125	149	58	54	0.41 kg
DCL/DML 162s	mm	110	55	55	126	142	80	76	0.77 kg
DCL/DML 162.5s	mm	110	55	55	128	146	80	76	0.78 kg
DCL/DML 163s	mm	110	55	55	129	148	80	76	0.78 kg
DCL/DML 164s	mm	110	55	55	131	152	80	76	0.79 kg
DCL/DML 165s	mm	110	55	55	134	158	80	76	0.80 kg
DCL/DML 166s	mm	110	55	55	140	170	80	76	0.82 kg
DCL/DML 167s	mm	110	55	55	136	172	80	76	0.84 kg

Dimensions and weights
(cont.)

Solder connections

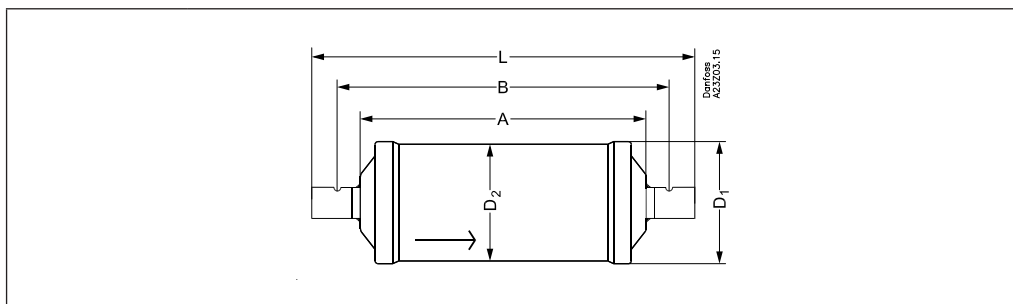

Type		A	A ₁	A ₂	B	L	D ₁	D ₂	Weight
DCL/DML 303s	mm	186	-	-	205	224	80	76	1.29 kg
DCL/DML 304s	mm	186	-	-	207	228	80	76	1.30 kg
DCL/DML 305s	mm	186	-	-	210	234	80	76	1.31 kg
DCL/DML 306s	mm	186	-	-	216	246	80	76	1.33 kg
DCL/DML 307s	mm	186	-	-	212	248	80	76	1.35 kg
DCL/DML 309s	mm	186	-	-	207	249	80	76	1.36 kg
DCL/DML 414s	mm	187	-	-	208	229	93	89	2.03 kg
DCL/DML 415s	mm	187	-	-	211	235	93	89	2.04 kg
DCL/DML 417s	mm	187	-	-	213	249	93	89	2.08 kg
DCL/DML 419s	mm	187	-	-	208	250	93	89	2.09 kg
DCL/DML 604s	mm	337	-	-	358	379	80	76	2.34 kg
DCL/DML 607s	mm	337	-	-	363	399	80	76	2.39 kg
DCL/DML 609s	mm	337	-	-	358	400	80	76	2.40 kg
DCL/DML 757s	mm	338	-	-	364	400	93	89	3.38 kg
DCL/DML 759s	mm	338	-	-	359	401	93	89	3.39 kg

Conversions

$$\text{Drops of water} = \frac{(\text{kg of refrigerant} \times (\text{Initial PPM of water} - \text{Final PPM of water}))}{50}$$

See ARI standard 710-86 for recommended initial and final PPM values for different refrigerants.